

# CC Series

According to ISO 15552 standards



ISO 9001  
BUREAU VERITAS  
Certification

N° IT275286





## Cylinders according to ISO 15552 standards - Series CC

Bores Ø : 32 - 40 - 50 - 63 - 80 - 100 - 125 mm.

### SERIES CC



Cylinders designed with lightened shape

According to ISO 15552 standards

Caps in die-cast aluminium, painted

Piston rod in steel C45, grounded and hard chromium plated

Profiled tube in anodized aluminium, internally gauged

"T" grooves for sensors, on one side

Adjustable end of stroke pneumatic cushions

Piston in aluminium with magnetic ring

Sensors and mounting accessories

### TECHNICAL FEATURES

<b>Construction</b>	Caps fixed on profiled tube by bolts
<b>Function</b>	Double acting, single acting on request
<b>Standard materials</b>	Caps in die-cast aluminium painted, piston rod in steel C45 grounded and hard chromium plated, profiled tube in anodized aluminium internally gauged, piston in aluminium, seals in NBR - PU
<b>Note about the materials</b>	According to Directive REACH (1907/2006/CE and s.a.s.)
<b>Bores</b>	Ø 32, 40, 50, 63, 80, 100, 125 mm
<b>Standard strokes (min. - max.)</b>	Ø 32, 40, 50: 25 mm ÷ 400 mm Ø 63, 80: 25 mm ÷ 600 mm Ø 100, 125: 50 mm ÷ 1000 mm
<b>Special strokes (on request)</b>	Up to 3000 mm
<b>Working temperature</b>	0 ÷ 80°C (-20°C with dry air, in order to avoid formation of ice) 0 ÷ 150°C (option in FKM)
<b>Working pressure</b>	1 ÷ 10 bar
<b>Fluid</b>	Filtered air without lubrication, according to ISO 8573-1:2010 [7:4:4]
<b>Speed</b>	10 ÷ 1000 mm/sec

### TECHNICAL DATA

Bore Ø (mm)	32	40	50	63	80	100	125
<b>Ports</b>	1/8"	1/4"	1/4"	3/8"	3/8"	1/2"	1/2"
<b>Piston rod Ø (mm)</b>	12	16	20	20	25	25	32
<b>Thread of the piston rod</b>	M10 x 1,25	M12 x 1,25	M16 x 1,5	M16 x 1,5	M20 x 1,5	M20 x 1,5	M27 x 2
<b>Theoretical push thrust at 6 bar (N)</b>	482	754	1178	1870	3016	4710	7363
<b>Theoretical pull thrust at 6 bar (N)</b>	414	633	990	1680	2722	4416	6882
<b>Air consumption at 6 bar in push (NI/cm)</b>	0,056	0,088	0,137	0,218	0,350	0,550	0,860
<b>Air consumption at 6 bar in pull (NI/cm)</b>	0,048	0,074	0,114	0,195	0,320	0,510	0,790
<b>Cushioning stroke</b>	20	20	25	25	35	35	30

### STANDARD STROKES

Ø	25	50	75	80	100	125	150	160	200	250	300	350	400	500	600	700	800	1000
<b>32</b>	x	x	x	x	x	x	x	x	x	x	x	x	x					
<b>40</b>	x	x	x	x	x	x	x	x	x	x	x	x	x					
<b>50</b>	x	x	x	x	x	x	x	x	x	x	x	x	x					
<b>63</b>	x	x	x	x	x	x	x	x	x	x	x	x	x	x	x			
<b>80</b>	x	x	x	x	x	x	x	x	x	x	x	x	x	x	x			
<b>100</b>		x	x	x	x	x	x	x	x	x	x	x	x	x	x	x	x	x
<b>125</b>		x	x	x	x	x	x	x	x	x	x	x	x	x	x	x	x	x

x = Double acting

ORDERING CODE

(Example of code)

CCM	P	050	0100	B
-----	---	-----	------	---

**SERIES**

CCM = standard, magnetic, with end of stroke pneumatic cushions

**PISTON ROD OPTIONS**

P = double ended  
Null = standard

**BORE**

032 = Ø 32 mm  
040 = Ø 40 mm  
050 = Ø 50 mm  
063 = Ø 63 mm  
080 = Ø 80 mm  
100 = Ø 100 mm  
125 = Ø 125 mm

**PISTON ROD STROKE**

See table "standard strokes", other strokes available on request

**MANUFACTURING VARIANTS**

B = extended piston rod for locking unit  
NX = piston rod and nut in stainless steel AISI 304 (X5 Cr Ni 1810)  
FKM = seals for high temperatures ( 0°C - 150°C)  
FKMS = rod seal in FKM, others as standard  
Null = no variants to the standard

STANDARD MATERIALS

POS	DESCRIPTION	MATERIAL	POS	DESCRIPTION	MATERIAL
①	Caps	Die-cast aluminium gray painted	⑪	Rod	Chromed steel C45, 20 µm
②	Piston rod seal	Poliurethane (PU)	⑫	Rod nut	Zinc-plated steel
③	Guide bushing	Sintered bronze	⑬	Half-piston	Die-cast aluminium
④	Cushion seal	Nitril rubber (NBR)	⑭	Piston seal	Nitril rubber (NBR)
⑤	Cap seal	Nitril rubber (NBR)	⑮	Piston seal - rod	Nitril rubber (NBR)
⑥	Cushion screw	Nickel-plated brass	⑯	Magnet	Ferrite
⑦	Cushion screw seal	Nitril rubber (NBR)	⑰	Wear ring	Polyoxymethylene (POM)
⑧	Retaining ring	Spring steel	⑱	Piston nut - rod	Zinc-plated steel
⑨	Bolt for fixing cap	Zinc-plated steel			
⑩	Profiled tube	Extruded aluminum EN AW-6060 T6 gauged and anodized			

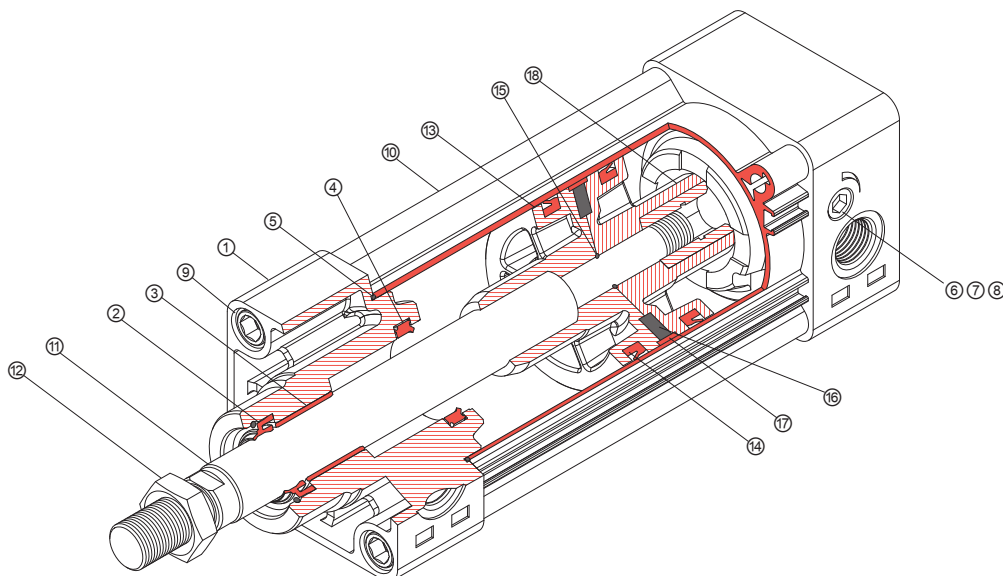

CCM...

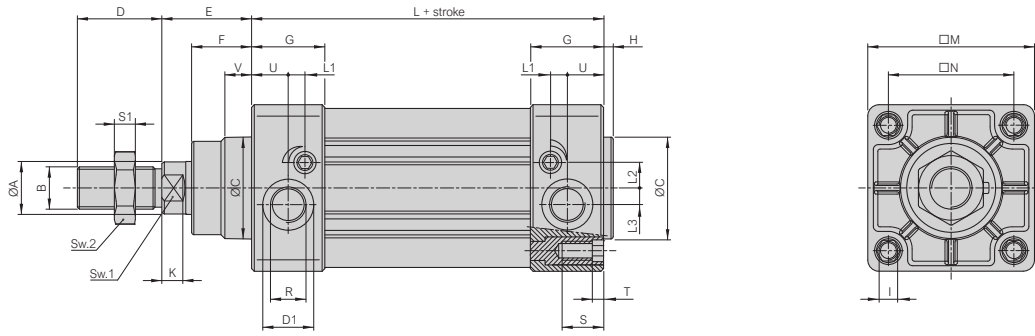

Bore	Ø A	B	Ø C	D	D1	E	F	G	H	I	K	L+	L1	L2	L3	□ M	□ N	R	S	S1	SW1	SW2	T	U	V			
mm	f7		d11	$\frac{0}{-2}$														Min	Ch	Ch								
32	12	M10 x 1,25	30	22	15	26		19	27	3	M6	5	94	±0,4	7	6	5,5	47	32,5		Gas 1/8"	16	6	10	17	6	12	8
40	16	M12 x 1,25	35	24	18	30	±1,4	21	31	3,5	M6	5	105	±0,7	6	8,5	6	53	38	±0,5	Gas 1/4"	16	7	13	17	6	15	10
50	20	M16 x 1,5	40	32	18	37		27	31	3,5	M8	5,5	106		6,5	8,5	7,5	65	46,5	±0,6	Gas 1/4"	16	8	17	23	7	15,5	10
63	20	M16 x 1,5	45	32	23	37		27	33	4	M8	5,5	121	±0,8	7,5	11,5	7,5	75	56,5		Gas 3/8"	16	8	17	23	7	16,5	12
80	25	M20 x 1,5	45	40	23	46	±1,8	33	36	4	M10	7	128	±0,7	7,5	13,5	8,5	95	72	±0,7	Gas 3/8"	17	10	22	26	7	19	15
100	25	M20 x 1,5	55	40	30	51		36	37	4	M10	7	138	±1	8,5	13,5	9,5	114	89		Gas 1/2"	17	10	22	28	7	18	15
125	32	M27 x 2	60	54	30	65	±2,2	40	45,2	4	M12	8	160		12	18	10	140	110	±1,1	Gas 1/2"	20	13,5	27	41	9	23	10

CCMP...

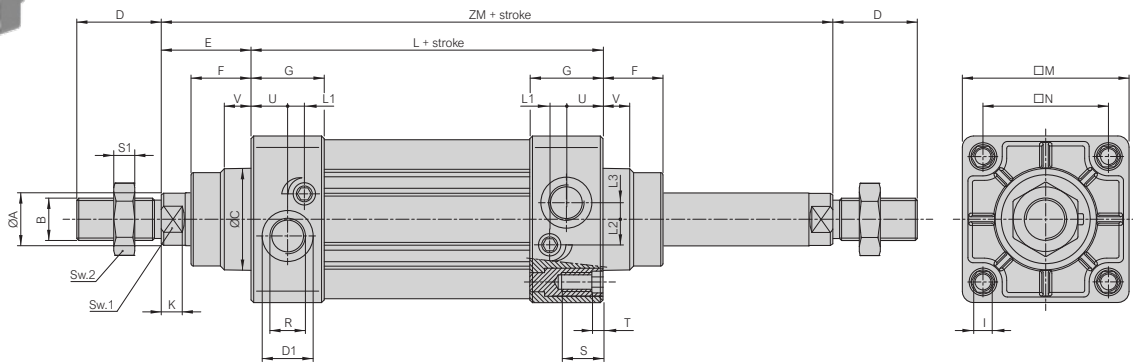

Bore	Ø A	B	Ø C	D	D1	E	F	G	I	K	L+	L1	L2	L3	□ M	□ N	R	S	S1	SW1	SW2	T	U	V	ZM+			
mm	f7		d11	$\frac{0}{-2}$														Min	Ch	Ch								
32	12	M10 x 1,25	30	22	15	26		19	27	M6	5	94	±0,4	7	6	5,5	47	32,5		Gas 1/8"	16	6	10	17	6	13	8	146
40	16	M12 x 1,25	35	24	18	30	±1,4	21	31	M6	5	105	±0,7	6	8,5	6	53	38	±0,5	Gas 1/4"	16	7	13	17	6	17	10	165
50	20	M16 x 1,5	40	32	18	37		27	31	M8	5,5	106		6,5	8,5	7,5	65	46,5	±0,6	Gas 1/4"	16	8	17	23	7	15,5	10	180
63	20	M16 x 1,5	45	32	23	37		27	33	M8	5,5	121	±0,8	7,5	11,5	7,5	75	56,5		Gas 3/8"	16	8	17	23	7	16,5	12	195
80	25	M20 x 1,5	45	40	23	46	±1,8	33	36	M10	7	128	±0,7	7,5	13,5	8,5	95	72	±0,7	Gas 3/8"	17	10	22	26	7	16,5	15	220
100	25	M20 x 1,5	55	40	30	51		36	37	M10	7	138	±1	8,5	13,5	9,5	114	89		Gas 1/2"	17	10	22	28	7	18,5	15	240
125	32	M27 x 2	60	54	30	65	±2,2	40	45,2	M12	8	160		12	18	10	140	110	±1,1	Gas 1/2"	20	13,5	27	41	9	23	10	290

ACCESSORIES

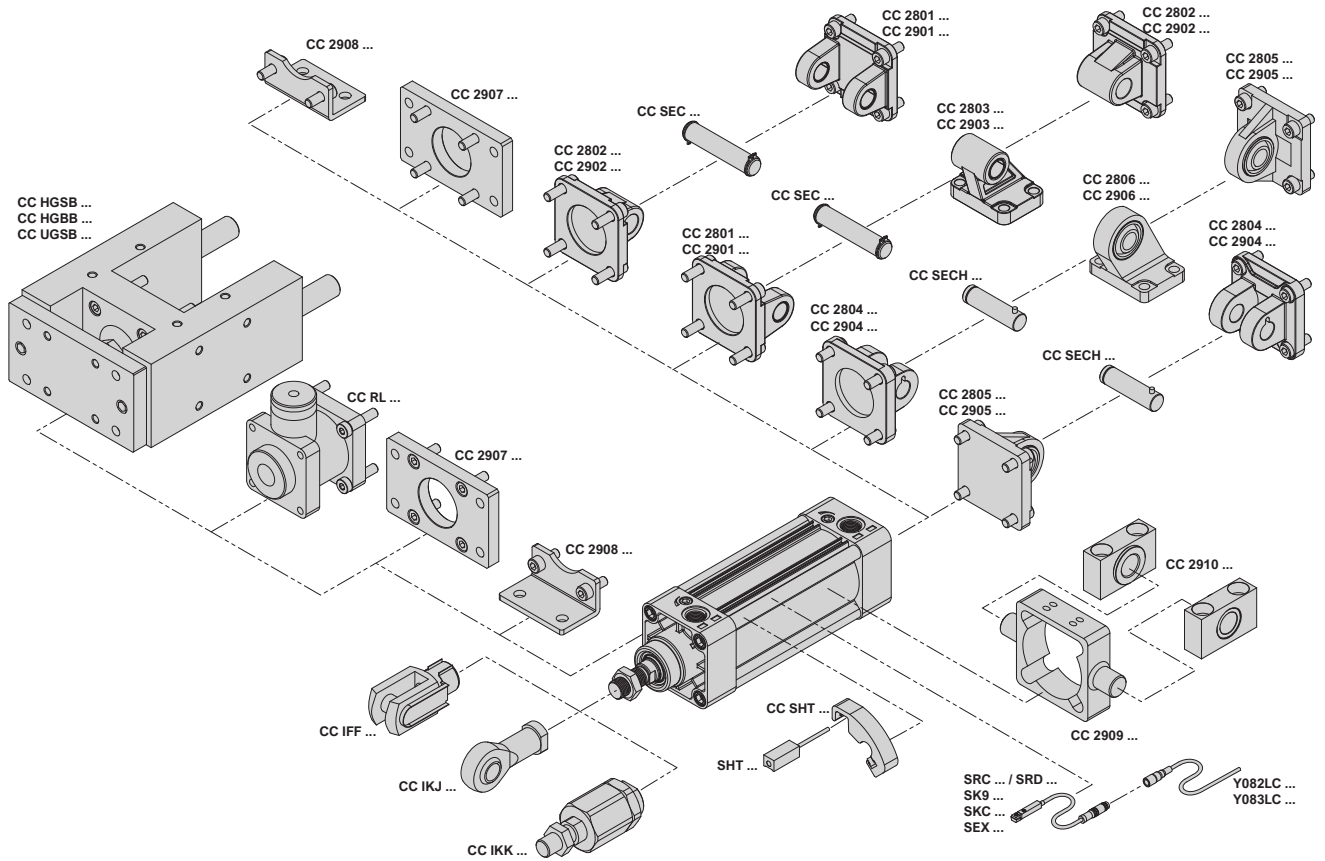

All mounting accessories are supplied complete with screws for fixing to cylinder

	CC IFF ... Female clevis	CC IKJ ... Self-lubricating oscillating joint	CC IKK ... Self-aligning joint angular and radial	CC 2801 ... Female hinge (MP2)	CC 2901 ... Female hinge (MP2)	CC 2802 ... Male hinge (MP4)	CC 2902 ... Male hinge (MP4)	CC 2803 ... Square joint at 90° (AB7)	CC 2903 ... Square joint at 90° (AB7)	CC 2804 ... Narrow female hinge (AB6)
Ø	Page 1.3.10.6	Page 1.3.10.6	Page 1.3.10.6	Page 1.3.10.7	Page 1.3.10.7	Page 1.3.10.7	Page 1.3.10.7	Page 1.3.10.7	Page 1.3.10.7	Page 1.3.10.7
32	CC IFF 032	CC IKJ 032	CC IKK 032	CC 2801 032	CC 2901 032	CC 2802 032	CC 2902 032	CC 2803 032	CC 2903 032	CC 2804 032
40	CC IFF 040	CC IKJ 040	CC IKK 040	CC 2801 040	CC 2901 040	CC 2802 040	CC 2902 040	CC 2803 040	CC 2903 040	CC 2804 040
50	CC IFF 050	CC IKJ 050	CC IKK 050	CC 2801 050	CC 2901 050	CC 2802 050	CC 2902 050	CC 2803 050	CC 2903 050	CC 2804 050
63	CC IFF 063	CC IKJ 063	CC IKK 063	CC 2801 063	CC 2901 063	CC 2802 063	CC 2902 063	CC 2803 063	CC 2903 063	CC 2804 063
80	CC IFF 080	CC IKJ 080	CC IKK 080	CC 2801 080	CC 2901 080	CC 2802 080	CC 2902 080	CC 2803 080	CC 2903 080	CC 2804 080
100	CC IFF 100	CC IKJ 100	CC IKK 100	CC 2801 100	CC 2901 100	CC 2802 100	CC 2902 100	CC 2803 100	CC 2903 100	CC 2804 100
125	CC IFF 125	CC IKJ 125	CC IKK 125	CC 2801 125	CC 2901 125	CC 2802 125	CC 2902 125	CC 2803 125	CC 2903 125	CC 2804 125
	Clevis and lockable pins in galvanized steel	Joint in galvanized steel, bush in sinterized bronze	Joint and nut in galvanized steel, Pin in blacked steel	Light alloy	Painted steel black cataphoresis	Light alloy	Painted steel black cataphoresis	Light alloy	Painted steel black cataphoresis	Light alloy

	CC 2904 ... Narrow female hinge (AB6)	CC 2805 ... Narrow male hinge with articulated head (MP6)	CC 2905 ... Narrow male hinge with articulated head (MP6)	CC 2806 ... Square joint at 90° with articulated head	CC 2906 ... Square joint at 90° with articulated head	CC 2907 ... Front and rear flange (MF1-MF2)	CC 2908 ... Low foot pedestal (MS1)	CC 2909 ... Adjustable intermediate hinge (MT4)	CC 2910 ... Support for intermediate hinge (AT4)
Ø	Page 1.3.10.7	Page 1.3.10.8	Page 1.3.10.8	Page 1.3.10.8	Page 1.3.10.8	Page 1.3.10.8	Page 1.3.10.8	Page 1.3.10.9	Page 1.3.10.9
32	CC 2904 032	CC 2805 032	CC 2905 032	CC 2806 032	CC 2906 032	CC 2907 032	CC 2908 032	CC 2909 032	CC 2910 032
40	CC 2904 040	CC 2805 040	CC 2905 040	CC 2806 040	CC 2906 040	CC 2907 040	CC 2908 040	CC 2909 040	CC 2910 040
50	CC 2904 050	CC 2805 050	CC 2905 050	CC 2806 050	CC 2906 050	CC 2907 050	CC 2908 050	CC 2909 050	CC 2910 050
63	CC 2904 063	CC 2805 063	CC 2905 063	CC 2806 063	CC 2906 063	CC 2907 063	CC 2908 063	CC 2909 063	CC 2910 063
80	CC 2904 080	CC 2805 080	CC 2905 080	CC 2806 080	CC 2906 080	CC 2907 080	CC 2908 080	CC 2909 080	CC 2910 080
100	CC 2904 100	CC 2805 100	CC 2905 100	CC 2806 100	CC 2906 100	CC 2907 100	CC 2908 100	CC 2909 100	CC 2910 100
125	CC 2904 125	CC 2805 125	CC 2905 125	CC 2806 125	CC 2906 125	CC 2907 125	CC 2908 125	CC 2909 125	CC 2910 125
	Painted steel black cataphoresis	Light alloy	Painted steel black cataphoresis	Light alloy	Painted steel black cataphoresis	White zinc coating steel	White zinc coating steel	White zinc coating steel	White zinc coating steel Bush in sinterized bronze



**ACCESSORIES**

	<b>CC SEC ...</b> Pin for female hinge MP2 (AA4)	<b>CC SECH ...</b> Pin for female hinge MP6 (AA6)	<b>CC HGSB ...</b> Piston rod guide H shape with slide bearings support	<b>CC HGBB ...</b> Piston rod guide H shape with ball bearings support	<b>CC UGSB ...</b> Piston rod guide U shape with slide bearings support	<b>CC RL ...</b> Static locking unit	<b>CC SG ...</b> Standard seals kit	<b>CC SGV ...</b> High temperature seals kit	<b>CC SGVS ...</b> Seals kit, rod in FKM other as standard
<b>Ø</b>	Page 1.3.10.9	Page 1.3.10.9	Page 1.3.10.10	Page 1.3.10.10	Page 1.3.10.11	Page 1.3.10.12			
<b>32</b>	CC SEC 032	CC SECH 032	CC HGSB 032	CC HGBB 032	CC UGSB 032	CC RL 032	CC SG 032	CC SGV 032	CC SGVS 032
<b>40</b>	CC SEC 040	CC SECH 040	CC HGSB 040	CC HGBB 040	CC UGSB 040	CC RL 040	CC SG 040	CC SGV 040	CC SGVS 040
<b>50</b>	CC SEC 050	CC SECH 050	CC HGSB 050	CC HGBB 050	CC UGSB 050	CC RL 050	CC SG 050	CC SGV 050	CC SGVS 050
<b>63</b>	CC SEC 063	CC SECH 063	CC HGSB 063	CC HGBB 063	CC UGSB 063	CC RL 063	CC SG 063	CC SGV 063	CC SGVS 063
<b>80</b>	CC SEC 080	CC SECH 080	CC HGSB 080	CC HGBB 080	CC UGSB 080	CC RL 080	CC SG 080	CC SGV 080	CC SGVS 080
<b>100</b>	CC SEC 100	CC SECH 100	CC HGSB 100	CC HGBB 100	CC UGSB 100	CC RL 100	CC SG 100	CC SGV 100	CC SGVS 100
<b>125</b>	CC SEC 125	CC SECH 125	CC HGSB 125	CC HGBB 125	CC UGSB 125	CC RL 125	CC SG 125	CC SGV 125	CC SGVS 125
	White zinc coating steel	White zinc coating steel	Body: Anodised aluminium Rods: Chrome plated steel Bush: Sinterized bronze	Body: Anodised aluminium Rods: Chrome plated steel Bush: Spherical bearings	Body: Anodised aluminium Rods: Chrome plated steel Bush: Sinterized bronze	Body: Anodised aluminium Jaws: Brass Springs: Spring steel	Rod seals: Polyurethane Other seals: NBR	Seals in FKM	Rod seals: FKM Other seals: NBR

	<b>SR ...</b> NC sensors REED / HALL	<b>SK9 ...</b> IP69K sensor PNP	<b>SKC ...</b> Precise position sensor PNP	<b>SEX ...</b> ATEX IIG sensor PNP	<b>SHT ...</b> High temperature sensor REED	<b>Y082LC / Y083LC</b> Straight connectors	<b>CC SHT ...</b> Bracket for sensor SHT
<b>Ø</b>	Page 1.3.10.13	Page 1.3.10.14	Page 1.3.10.14	Page 1.3.10.14	Page 1.3.10.15	Page 1.3.10.15	Page 1.3.10.16
<b>32</b>							CC SHT 032
<b>40</b>							CC SHT 040
<b>50</b>							CC SHT 050
<b>63</b>							CC SHT 063
<b>80</b>							CC SHT 080
<b>100</b>							CC SHT 100
<b>125</b>							CC SHT 125
	Sensor: PA6 Cable: PUR	Sensor: PA12 Cable: PUR	Sensor: PA Cable: PUR	Sensor: PA Cable: PVC	Sensor: Aluminium Cable: PTFE	Connector: PVC Contacts: Gilded brass Cable: PVC	Anodised aluminium

**PISTON ROD ACCESSORIES**

CC IFF ... Female clevis	Bore mm	Code	AA	AB	∅ AC h11	AD +0,30 -0,16	AE ±0,5	AF ±0,5	AG ±0,4	AH ±0,2	AL		
	32	CC IFF 032	10	+0,37 +0,15	M10 x 1,25	10	20	20	52	40	23	3	
	40	CC IFF 040	12		+0,70 +0,15	M12 x 1,25	12	24	24	62	48	28	4
	50	CC IFF 050	16			M16 x 1,5	16	32	32	83	64	36	6
	63	CC IFF 063	16			M16 x 1,5	16	32	32	83	64	36	6
	80	CC IFF 080	20			M20 x 1,5	20	40	40	105	80	44	5
	100	CC IFF 100	20			M20 x 1,5	20	40	40	105	80	44	5
	125	CC IFF 125	30			M27 x 2	30	55	54	148	110	65	-

Clevis and clip in zinc plated steel / 1 piece each package

CC IKJ ... Self-lubricating oscillating joint	Bore mm	Code	AB	∅ AC H7	AM	AN	AO	AP	AQ	∅ AR	∅ AS	∅ AT	AU	AV	AZ
	32	CC IKJ 032	M10 x 1,25	10	20	17	28	14	10,5	12,9	15	19	6,5	43	57
	40	CC IKJ 040	M12 x 1,25	12	22	19	32	16	12	15,4	17,5	22	6,5	50	66
	50	CC IKJ 050	M16 x 1,5	16	28	22	42	21	15	19,3	22	27	8	64	85
	63	CC IKJ 063	M16 x 1,5	16	28	22	42	21	15	19,3	22	27	8	64	85
	80	CC IKJ 080	M20 x 1,5	20	33	30	50	25	18	24,3	27,5	34	10	77	102
	100	CC IKJ 100	M20 x 1,5	20	33	30	50	25	18	24,3	27,5	34	10	77	102
	125	CC IKJ 125	M27 x 2	30	51	41	70	37	25	34,8	40	50	15	110	145

Joint in zinc plated steel, bush in sintered bronze, ring in hardened bearing steel / 1 piece each package

CC IKK ... Self-aligning joint angular and radial	Bore mm	Code	A	B	C	D	E	∅ F	∅ G	∅ H	L	M	Ch1	Ch2	Ch3	∅ β	Static load daN
	32	CC IKK 032	M10 x 1,25	71,5	20	7,5	35	14	22	32	2	22	12	19	30	8	500
	40	CC IKK 040	M12 x 1,25	75,5	24	7,5	35	14	22	32	2	22	12	19	30	8	500
	50	CC IKK 050	M16 x 1,5	104	32	10	53	22	32	45	2	30	20	27	41	6	1000
	63	CC IKK 063	M16 x 1,5	104	32	10	53	22	32	45	2	30	20	27	41	6	1000
	80	CC IKK 080	M20 x 1,5	119	40	10	53	22	32	45	2	37	20	27	41	6	1000
	100	CC IKK 100	M20 x 1,5	119	40	10	53	22	32	45	2	37	20	27	41	6	1000
	125	CC IKK 125	M27 x 2	147	54	10	60	32	57	70	2	48	24	54	65	8	3000

Joint and nut in zinc plated steel, pin in burnished steel / 1 piece each package



**MOUNTING ACCESSORIES**

CC 2801 ... / CC 2901 ... Female hinge (MP2)		Bore mm	Code	A+	B	C ±0,2	D H9	E H14	F h14	M	H	Fixing screw ISO 4762
	32	CC 2801 032 CC 2901 032	142	±1,25	13	22	10	26	45	45	10	M6 x 18
	40	CC 2801 040 CC 2901 040	160		16	25	12	28	52	52	12	M6 x 18
	50	CC 2801 050 CC 2901 050	170		16	27	12	32	60	65	12	M8 x 25
	63	CC 2801 063 CC 2901 063	190	±1,6	21	32	16	40	70	75	16	M8 x 25
	80	CC 2801 080 CC 2901 080	210		22	36	16	50	90	95	16	M10 x 30
	100	CC 2801 100 CC 2901 100	230		27	41	20	60	110	115	20	M10 x 30
	125	CC 2801 125 CC 2901 125	275	±2	30	50	25	70	130	140	25	M12 x 35

CC 2801 ... Light alloy / CC 2901 ... Painted steel black cataphoresis / 1 piece each package + 4 screws for fixing to cylinder

CC 2802 ... / CC 2902 ... Male hinge (MP4)		Bore mm	Code	A+	B	C ±0,2	D H9	E	M	H	Fixing screw ISO 4762	
	32	CC 2802 032 CC 2902 032	142	±1,25	13	22	10	26	-0,2 -0,6	45	10	M6 x 18
	40	CC 2802 040 CC 2902 040	160		16	25	12	28		52	12	M6 x 18
	50	CC 2802 050 CC 2902 050	170		16	27	12	32		65	12	M8 x 25
	63	CC 2802 063 CC 2902 063	190	±1,6	21	32	16	40		75	16	M8 x 25
	80	CC 2802 080 CC 2902 080	210		22	36	16	50		95	16	M10 x 30
	100	CC 2802 100 CC 2902 100	230		27	41	20	60		115	20	M10 x 30
	125	CC 2802 125 CC 2902 125	275	±2	30	50	25	70		-0,5 -1,2	140	25

CC 2802 ... Light alloy / CC 2902 ... Painted steel black cataphoresis / 1 piece each package + 4 screws for fixing to cylinder

CC 2803 ... / CC 2903 ... Square joint at 90° (AB7)		Bore mm	Code	A+	E	N JS15	P JS14	Q JS14	R	S	T JS14	Ø U1 H13	V	
	32	CC 2803 032 CC 2903 032	142	±1,25	26	-0,2 -0,6	32	21	18	31	51	38	6,6	6,4
	40	CC 2803 040 CC 2903 040	160		28		36	24	22	35	54	41	6,6	8,4
	50	CC 2803 050 CC 2903 050	170		32		45	33	30	45	65	50	9	10,4
	63	CC 2803 063 CC 2903 063	190	±1,6	40		50	37	35	50	67	52	9	12,4
	80	CC 2803 080 CC 2903 080	210		50		63	47	40	60	86	66	11	11,5
	100	CC 2803 100 CC 2903 100	230		60		71	55	50	70	96	76	11	14,5
	125	CC 2803 125 CC 2903 125	275	±2	70		-0,5 -1,2	90	70	60	90	124	94	14

CC 2803 ... Light alloy / CC 2903 ... Painted steel black cataphoresis / 1 piece each package

CC 2804 ... / CC 2904 ... Narrow female hinge (AB6)		Bore mm	Code	A+	B1	C ±0,2	D1 F7	E1 H14	F1 d12	H1	M	Fixing screw ISO 4762
	32	CC 2804 032 CC 2904 032	142	±1,25	13	22	10	14	34	10	45	M6 x 18
	40	CC 2804 040 CC 2904 040	160		16	25	12	16	40	12	52	M6 x 18
	50	CC 2804 050 CC 2904 050	170		16	27	16	21	45	14	65	M8 x 20
	63	CC 2804 063 CC 2904 063	190	±1,6	21	32	16	21	51	18	75	M8 x 20
	80	CC 2804 080 CC 2904 080	210		22	36	20	25	65	20	95	M10 x 25
	100	CC 2804 100 CC 2904 100	230		27	41	20	25	75	22	115	M10 x 25
	125	CC 2804 125 CC 2904 125	275	±2	30	50	30	37	97	25	140	M12 x 35

CC 2804 ... Light alloy / CC 2904 ... Painted steel black cataphoresis / 1 piece each package + 4 screws for fixing to cylinder

**MOUNTING ACCESSORIES**

CC 2805 ... / CC 2905 ... Narrow male hinge with articulated head (MP6)		Bore mm	Code	A+	B1	C ±0,2	D H9	E1 ±0,2	M	H2	Fixing screw ISO 4762
	32	CC 2805 032 CC 2905 032	142	±1,25	13	22	10	14	45	16	M6 x 18
	40	CC 2805 040 CC 2905 040	160		16	25	12	16	52	19	M6 x 18
	50	CC 2805 050 CC 2905 050	170		16	27	12	21	65	21	M8 x 20
	63	CC 2805 063 CC 2905 063	190	±1,6	21	32	16	21	75	24	M8 x 20
	80	CC 2805 080 CC 2905 080	210		22	36	16	25	95	28,5	M10 x 25
	100	CC 2805 100 CC 2905 100	230		27	41	20	25	115	30	M10 x 25
	125	CC 2805 125 CC 2905 125	275		±2	30	50	25	37	140	40
CC 2805 ... Light alloy / CC 2905 ... Painted steel black cataphoresis / 1 piece each package + 4 screws for fixing to cylinder											

CC 2806 ... / CC 2906 ... Square joint at 90° with articulated head		Bore mm	Code	A+	E1 0 -0,1	N JS15	P JS15	Q JS14	R	S	T JS14	Ø U H13	V +0,5 0
	32	CC 2806 032 CC 2906 032	142	±1,25	14	32	21	18	31	51	38	6,6	8,5
	40	CC 2806 040 CC 2906 040	160		16	36	24	22	35	54	41	6,6	8,5
	50	CC 2806 050 CC 2906 050	170		21	45	33	30	45	65	50	9	10,5
	63	CC 2806 063 CC 2906 063	190	±1,6	21	50	37	35	50	67	52	9	10,5
	80	CC 2806 080 CC 2906 080	210		25	63	47	40	60	86	66	11	11,5
	100	CC 2806 100 CC 2906 100	230		25	71	55	50	70	96	76	11	12,5
	125	CC 2806 125 CC 2906 125	275		±2	37	90	70	60	90	124	94	13,5
CC 2806 ... Light alloy / CC 2906 ... Painted steel black cataphoresis / 1 piece each package													

CC 2907 ... Front and rear flange ISO (MF1-MF2)		Bore mm	Code	A1+	B2 ±0,2	C1 JS14	D2 JS14	E2 H13	F2	G	M	Fixing screw ISO 4762	
	32	CC 2907 032	130	±1,25	10	80	64	32	7	16	45	M6 x 18	
	40	CC 2907 040	145		10	90	72	36	9	20	±1,6	52	M6 x 18
	50	CC 2907 050	155		12	110	90	45	9	25	65	M8 x 20	
	63	CC 2907 063	170	±1,6	12	120	100	50	9	25	75	M8 x 20	
	80	CC 2907 080	190		16	150	126	63	12	30	±2	95	M10 x 20
	100	CC 2907 100	205		16	170	150	75	14	35	115	M10 x 20	
	125	CC 2907 125	245		±2	20	205	180	90	16	45	±2,5	140
CC 2907 ... White zinc plated steel / 1 piece each package + 4 screws for fixing to cylinder													

CC 2908 ... Low foot pedestal (MS1)		Bore mm	Code	A2+	B3 ±0,2	C2 JS14	E2 H14	Ø G1 H14	M JS16	N	Q1+	V1 ±0,5	Fixing screw ISO 4762	
	32	CC 2908 032	144	±1,25	24	35	32	7	45	32	142	4	M6 x 18	
	40	CC 2908 040	163		28	36	36	9	52	36	161	±1,25	4	M6 x 18
	50	CC 2908 050	175		32	47	45	9	65	45	170	5	M8 x 20	
	63	CC 2908 063	190	±1,6	32	45	50	9	75	50	185	5	M8 x 20	
	80	CC 2908 080	215		41	55	63	12	95	63	210	±1,6	6	M10 x 25
	100	CC 2908 100	230		41	57	75	14	115	71	220	6	M10 x 25	
	125	CC 2908 125	270		±2	45	70	90	16	140	90	250	±2	8
CC 2908 ... White zinc plated steel / 1 piece each package + 2 screws for fixing to cylinder														

**MOUNTING ACCESSORIES**

CC 2909 ... Adjustable intermediate hinge (MT4)	Bore mm	Code	A3 h14	B4 h14	C3	Ø D3 e9	E3	Xmin	Xmax +
	32	CC 2909 032	50	12	48,5	12	18	62	84
	40	CC 2909 040	63	16	59	16	20	71	94
	50	CC 2909 050	75	16	71	16	20	78	102
	63	CC 2909 063	90	20	84	20	26	83	112
	80	CC 2909 080	110	20	105	20	26	95	125
	100	CC 2909 100	132	25	129	25	32	104	136
	125	CC 2909 125	160	25	154	25	33	126,7	163.3

CC 2909 ... White zinc plated steel / 1 piece each package + 8 set head screws for fixing to cylinder

CC 2910 ... Support for intermediate hinge (AT4)	Bore mm	Code	A3 h14	A4	B5	C4	Ø D3 F7	E4 ±0,2	F3 ±0,5	Ø G2 H13	Ø G3 H13	M1	N1 ±0,1
	32	CC 2910 032	50	46	71	86	12	32	7	6,6	11	30	15
	40	CC 2910 040	63	55	87	105	16	36	9	9	15	36	18
	50	CC 2910 050	75	55	99	117	16	36	9	9	15	36	18
	63	CC 2910 063	90	65	116	136	20	42	11	11	18	40	20
	80	CC 2910 080	110	65	136	156	20	42	11	11	18	40	20
	100	CC 2910 100	132	75	164	189	25	50	13	14	20	50	25
	125	CC 2910 125	160	75	192	217	25	50	13	14	20	50	25

CC 2910 ... White zinc plated steel, bush in sintered bronze / 2 pieces each package

CC SEC ... Pin for female hinge MP2 (AA4)	Bore mm	Code	Ø EK e8	EL +0,3 0	L
	32	CC SEC 032	10	46	53
	40	CC SEC 040	12	53	60
	50	CC SEC 050	12	61	68
	63	CC SEC 063	16	71	78
	80	CC SEC 080	16	91	98
	100	CC SEC 100	20	111	118
	125	CC SEC 125	25	132	139

CC SEC ... White zinc plated steel / 1 piece each package + 2 retaining rings DIN 471

CC SECH ... Pin for female hinge MP6 (AA6)	Bore mm	Code	B	Ø EK f7	EL1 +0,5 +0,3	H 0 -0,5	L1	Ø P h12	
	32	CC SECH 032	4,5	10	32,5	14	41	3	
	40	CC SECH 040	6	0 -1	12	38	16	48	4
	50	CC SECH 050	6		16	43	20	54	4
	63	CC SECH 063	6		16	49	20	60	4
	80	CC SECH 080	6		20	63	24	75	4
	100	CC SECH 100	6		20	73	24	85	4
	125	CC SECH 125	9	0 -2	30	94	36	110	6

CC SECH ... White zinc plated steel / 1 piece each package + 1 retaining ring DIN 471

GUIDE UNITS

CC HGSB ...

Piston rod guide H shape with slide bearings support

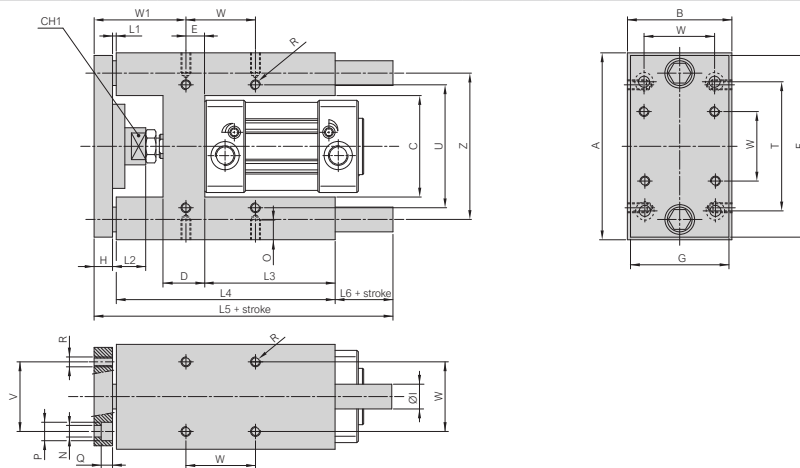

Bore mm	Code	A	B	C	Ch1	D	E	F	G	H	Ø1	L1	L2	L3	L4	L5+	L6+	N	O	P	Q	R	T	U	W	W1	Z
32	CC HGSB 032	97	49	51	15	24	4,3	93	45	12	12	3	19	75	125	187	47	6,6	12	11	6,5	M6	78	61	32,5	60,7	74
40	CC HGSB 040	115	58	58,2	15	28	11	112	55	12	16	3	24	80	140	207	52	6,6	12	11	6,5	M6	84	69	38	64	87
50	CC HGSB 050	137	70	70,2	20	34	18,8	134	65	15	20	3	27	78	148	223	57	9	16	15	8,5	M8	100	85	46,5	69,2	104
63	CC HGSB 063	152	85	85,2	20	34	15,3	147	80	15	20	3	27	106	178	243	47	9	16	15	9	M8	105	100	56,5	74,7	119
80	CC HGSB 080	189	105	105,5	26	50	25	180	100	20	25	3	27	111	195	267	49	11	20	18	11	M10	130	130	72	82	148
100	CC HGSB 100	213	130	130,5	26	55	30	206	120	20	25	3	27	128	218	290	49	11	20	18	11	M10	150	150	89	83	173

CC HGSB ... Body and plate in anodized aluminium, piston rods in chromium plated steel, joint in stainless steel, bushes in sintered bronze, seals in NBR / 1 piece each package + 4 screws for fixing to cylinder

CC HGBB ...

Piston rod guide H shape with ball bearings support

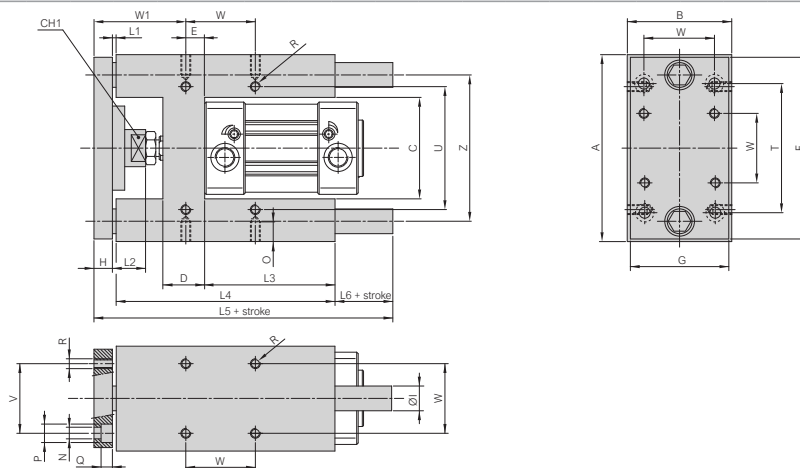

Bore mm	Code	A	B	C	Ch1	D	E	F	G	H	Ø1	L1	L2	L3	L4	L5+	L6+	N	O	P	Q	R	T	U	W	W1	Z
32	CC HGBB 032	97	49	51	15	24	4,3	93	45	12	12	3	19	75	125	187	47	6,6	12	11	6,5	M6	78	61	32,5	60,7	74
40	CC HGBB 040	115	58	58,2	15	28	11	112	55	12	16	3	24	80	140	207	52	6,6	12	11	6,5	M6	84	69	38	64	87
50	CC HGBB 050	137	70	70,2	20	34	18,8	134	65	15	20	3	27	78	148	223	57	9	16	15	8,5	M8	100	85	46,5	69,2	104
63	CC HGBB 063	152	85	85,2	20	34	15,3	147	80	15	20	3	27	106	178	243	47	9	16	15	9	M8	105	100	56,5	74,7	119
80	CC HGBB 080	189	105	105,5	26	50	25	180	100	20	25	3	27	111	195	267	49	11	20	18	11	M10	130	130	72	82	148
100	CC HGBB 100	213	130	130,5	26	55	30	206	120	20	25	3	27	128	218	290	49	11	20	18	11	M10	150	150	89	83	173

CC HGBB ... Body and plate in anodized aluminium, piston rods in chromium plated steel, joint in stainless steel, bushes in steel, seals in NBR / 1 piece each package + 4 screws for fixing to cylinder

GUIDE UNITS

CC UGSB ...

Piston rod guide U shape with slide bearings support

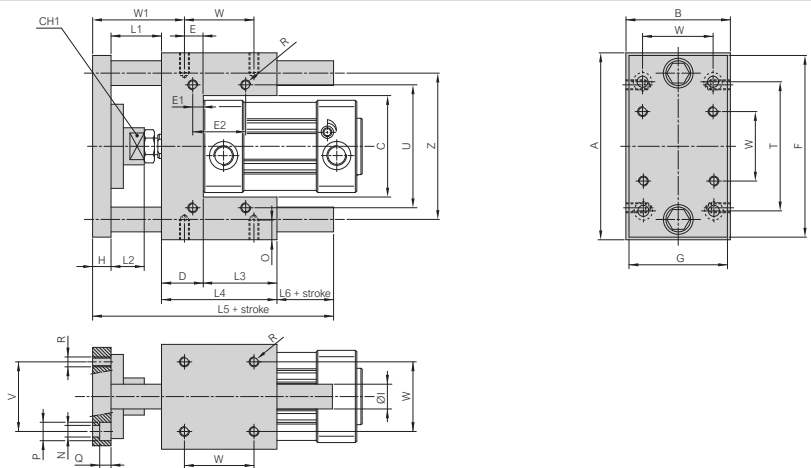

Bore mm	Code	A	B	C	Ch1	D	E	E1	E2	F	G	H	ØI	L1	L2	L3	L4	L5+	L6+	N	O	P	Q	R	T	U	W	W1	Z
32	CC UGSB 032	97	49	51	15	17	9,25	9,25	32,5	93	45	12	12	42	25	11	48	120	18	6,6	12	11	6,5	M6	78	61	32,5	61,75	74
40	CC UGSB 040	115	58	58,2	15	21	11	11	38	112	55	12	16	43	25	37	58	130	17	6,6	12	11	6,5	M6	84	69	38	65	87
50	CC UGSB 050	137	70	70,2	20	25	18,8	18,8	46,5	134	65	15	20	49	29	34	59	143	20	9	16	15	8,5	M8	100	85	46,5	70,2	104
63	CC UGSB 063	152	85	85,2	20	25	15,3	15,3	56,5	147	80	15	20	49	29	51	76	161	21	9	16	15	9	M8	105	100	56,5	73,7	119
80	CC UGSB 080	189	105	105,5	26	34	25	14	50	180	100	20	25	53	27	56	90	193	30	11	20	18	11	M10	130	130	72	82	148
100	CC UGSB 100	213	130	130,5	26	39	28,5	19	70	206	120	20	25	54	27	71	110	214	30	11	20	18	11	M10	150	150	59	84,5	173

CC UGSB ... Body and plate in anodized aluminium, piston rods in chromium plated steel, joint in stainless steel, bushes in sintered bronze, seals in NBR / 1 piece each package + 4 screws for fixing to cylinder

LOCKING UNIT

CC RL ...

Static locking unit

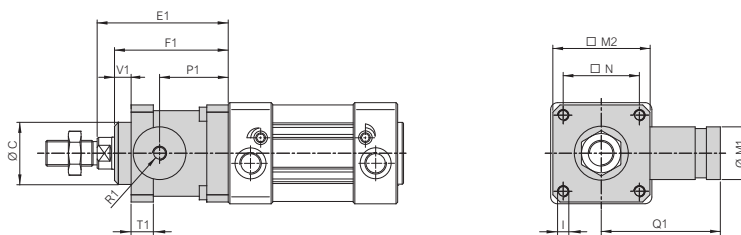

Bore mm	Code	Ø C d11	E1	F1 ±0,3	I	Ø M1 f8	M2	N	P1	Q1 ±0,15	R1	T1 ±0,3	V1	Fixing screw	Locking force N					
32	CC RL 032	30	74	±1,4	58	M6	20	45	±0,5	32,5	±0,25	31,5	±0,4	44,5	M5	13	10	M6 x 20	600	
40	CC RL 040	35	85		65	M6	24	50	±0,55	38		46,5		±0,3	45,5	61	Gas 1/8"	13	10	M6 x 20
50	CC RL 050	40	107		82	M8	30	60	±0,75	56,5	±0,4	49,5		85,5	Gas 1/8"	16	12	M8 x 30	1400	
63	CC RL 063	45	107	±1,8	82	M8	38	70	±0,75	56,5	±0,4	49,5	±0,5	85,5	Gas 1/8"	16	12	M8 x 30	2000	
80	CC RL 080	45	136		110	M10	48	90	±1,0	72	±0,45	61		85,5	Gas 1/8"	20	20	M10 x 35	3500	
100	CC RL 100	55	143		115	M10	48	105	±1,1	89	±0,5	65		115	Gas 1/8"	20	23	M10 x 35	5000	
125	CC RL 125	60	187	±2,2	167	M12	65	140	±1,1	110	±0,6	86,5	140	Gas 1/8"	30	45	M12 x 40	7500		

CC RL ... Body in anodized aluminium, jaws in brass, springs in spring steel / 1 piece each package + 4 screws for fixing to cylinder



END OF STROKE SENSORS TYPE SR

**SRC-61, SRC-21, SRC-27**

End of stroke sensor REED - 2 poles N.O.

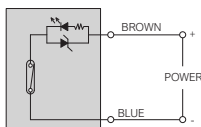
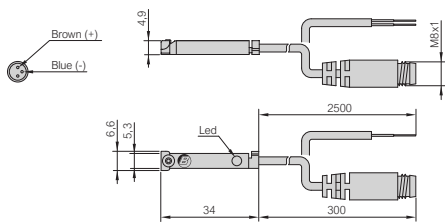

Technical features			
<b>Code</b>	SRC-61	SRC-21	SRC-27
<b>Version</b>	Cable 2 x 0,14 mm <sup>2</sup>	Cable 2 x 0,14 mm <sup>2</sup>	Connector M8 x 1 - 2 pin
<b>Sensor</b>	REED		
<b>Output</b>	Pure contact, normally open		
<b>Operating voltage</b>	5 ± 230 Vac / Vdc	5 ± 130 Vac / Vdc	5 ± 50 Vac / Vdc
<b>Switching current (max.)</b>	200 mA	200 mA	200 mA
<b>Contact rating (max.)</b>	10 W	6 W	6 W
<b>Voltage drop (max.)</b>	3 V	3 V	3 V
<b>Visual indicator</b>	LED yellow diode		
<b>Operating frequency</b>	1000 Hz		
<b>Temperature range</b>	-15 ÷ +70 °C		
<b>Enclosure classification (IEC 60529)</b>	IP67		
<b>Protection circuit</b>	Power source reverse polarity		
<b>Mounting</b>	Screw for "T" groove - Torque max. 0,1 Nm		

SRC-61, SRC-21, SRC-27 / Sensor in PA6, cable in PUR - 1 piece each package

**SRD-21, SRD-27**

End of stroke sensor REED - 3 poles N.O.

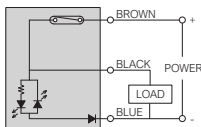
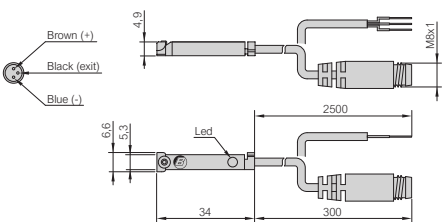

Technical features		
<b>Code</b>	SRD-21	SRD-27
<b>Version</b>	Cable 3 x 0,14 mm <sup>2</sup>	Connector M8 x 1 - 3 pin
<b>Sensor</b>	REED	
<b>Output</b>	PNP, normally open	
<b>Operating voltage</b>	5 ± 30 Vac / Vdc	
<b>Switching current (max.)</b>	200 mA	
<b>Contact rating (max.)</b>	6 W	
<b>Voltage drop (max.)</b>	0,7 V	
<b>Visual indicator</b>	LED yellow diode	
<b>Operating frequency</b>	1000 Hz	
<b>Temperature range</b>	-15 ÷ +70 °C	
<b>Enclosure classification (IEC 60529)</b>	IP67	
<b>Protection circuit</b>	Power source reverse polarity	
<b>Mounting</b>	Screw for "T" groove - Torque max. 0,1 Nm	

SRD-21, SRD-27 / Sensor in PA6, cable in PUR - 1 piece each package

**SRN-21, SRN-27**

End of stroke sensor HALL PNP - 3 poles N.O.

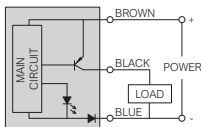
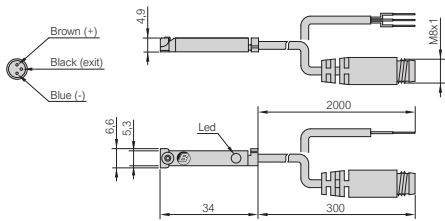

Technical features		
<b>Code</b>	SRN-21	SRN-27
<b>Version</b>	Cable 3 x 0,14 mm <sup>2</sup>	Connector M8 x 1 - 3 pin
<b>Sensor</b>	HALL	
<b>Output</b>	PNP, normally open	
<b>Operating voltage</b>	10 ± 30 Vdc	
<b>Switching current (max.)</b>	200 mA	
<b>Contact rating (max.)</b>	4 W	
<b>Voltage drop (max.)</b>	0,7 V	
<b>Visual indicator</b>	LED yellow diode	
<b>Operating frequency</b>	1000 Hz	
<b>Temperature range</b>	-15 ÷ +70 °C	
<b>Enclosure classification (IEC 60529)</b>	IP67	
<b>Protection circuit</b>	Power source reverse polarity	
<b>Mounting</b>	Screw for "T" groove - Torque max. 0,1 Nm	

SRN-21, SRN-27 / Sensor in PA6, cable in PUR - 1 piece each package

**END OF STROKE SENSORS TYPE SK9 with enclosure classification IP69K**

**SK9-21**  
End of stroke sensor HALL PNP - 3 poles N.O.

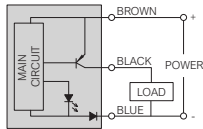
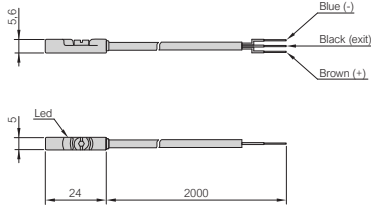

Technical features	
Code	SK9-21
Version	Cable 3 x 0,14 mm <sup>2</sup>
Sensor	HALL
Output	PNP, normally open
Operating voltage	10 ÷ 30 Vdc
Switching current (max.)	200 mA
Contact rating (max.)	6 W
Current consumption	10 mA (without load)
Voltage drop (max.)	2,2 V
Visual indicator	LED yellow diode: flashing (instable position) permanently light (stable position)
Operating frequency	1000 Hz
Temperature range	-30 ÷ +80 °C
Enclosure classification (DIN 40050)	IP69K
Protection circuit	Short-circuit, power source reverse polarity, power-up pulse
Mounting	Screw for "T" groove - Torque max. 0,3 Nm

SK9-21 / Sensor in PA12, cable in PUR - 1 piece each package

**END OF STROKE SENSORS TYPE SKC with precise positioning sistem**

**SKC-27**  
End of stroke sensor HALL PNP - 3 poles N.O.

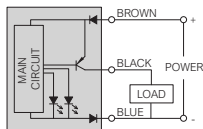
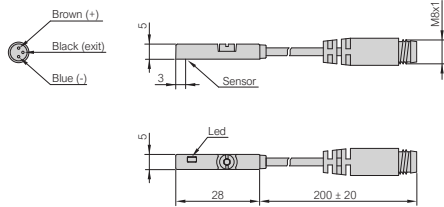

Technical features	
Code	SKC-27
Version	Connector M8 x 1 - 3 pin
Sensor	HALL
Output	PNP, normally open
Operating voltage	10 ÷ 28 Vdc
Switching current (max.)	80 mA
Contact rating (max.)	2 W
Current consumption	10 mA (24 Vdc)
Voltage drop (max.)	1,5 V
Leakage current (max.)	0,05 mA
Visual indicator	Two colors LED diode: red (instable position) green (stable position)
Operating frequency	1000 Hz
Temperature range	-10 ÷ +60 °C
Enclosure classification (IEC 60529)	IP67
Protection circuit	Short-circuit, power source reverse polarity, power-up pulse
Mounting	Screw for "T" groove - Torque max. 0,3 Nm

SKC-27 / Sensor in PA, cable in PUR - 1 piece each package

**END OF STROKE SENSORS TYPE SEX for potentially explosive environment ATEX**

**SEX-21**  
End of stroke sensor HALL PNP - 3 poles N.O.

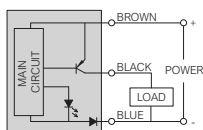
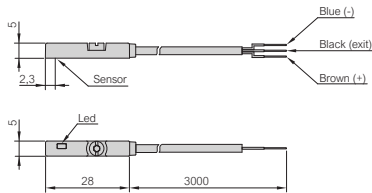

Technical features	
Code	SEX-21
Version	Cable 3 x 0,14 mm <sup>2</sup>
Sensor	HALL
Output	PNP, normally open
Operating voltage	10 ÷ 28 Vdc
Switching current (max.)	200 mA
Contact rating (max.)	5,5 W
Current consumption	10 mA (24 Vdc)
Voltage drop (max.)	1,5 V
Leakage current (max.)	0,05 mA
Visual indicator	LED yellow diode
Operating frequency	1000 Hz
Temperature range	-10 ÷ +70 °C
Enclosure classification (IEC 60529)	IP67
Protection circuit	Short-circuit, power source reverse polarity, power-up pulse
Mounting	Screw for "T" groove - Torque max. 0,3 Nm
ATEX marking (2014/34/EU)	II 3GD Ex ic IIB T4 Gc Ex ic IIIC T135°C Dc

SEX-21 / Sensor in PA, cable PVC - 1 piece each package

END OF STROKE SENSORS TYPE SHT for high temperature

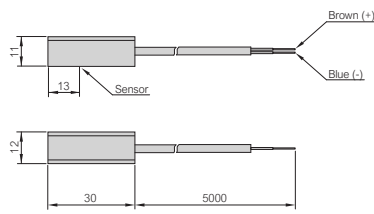
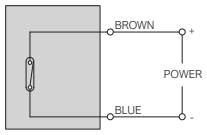
<p><b>SHT-21</b> End of stroke sensor REED - 2 poles N.O.</p> 	<p><b>Technical features</b></p>																												
	<table border="1"> <tr><td><b>Code</b></td><td>SHT-21</td></tr> <tr><td><b>Version</b></td><td>Cable 2 x 0,14 mm<sup>2</sup></td></tr> <tr><td><b>Sensor</b></td><td>REED</td></tr> <tr><td><b>Output</b></td><td>Pure contact, normally open</td></tr> <tr><td><b>Operating voltage</b></td><td>5 ÷ 240 Vac / Vdc</td></tr> <tr><td><b>Switching current (max.)</b></td><td>500 mA</td></tr> <tr><td><b>Contact rating (max.)</b></td><td>10 W</td></tr> <tr><td><b>Voltage drop (max.)</b></td><td>0,5 V</td></tr> <tr><td><b>Visual indicator</b></td><td>None</td></tr> <tr><td><b>Operating frequency</b></td><td>200 Hz</td></tr> <tr><td><b>Temperature range</b></td><td>-10 ÷ +140 °C</td></tr> <tr><td><b>Enclosure classification (IEC 60529)</b></td><td>IP67</td></tr> <tr><td><b>Protection circuit</b></td><td>None</td></tr> <tr><td><b>Mounting</b></td><td>Only with braket CC SHT</td></tr> </table>	<b>Code</b>	SHT-21	<b>Version</b>	Cable 2 x 0,14 mm <sup>2</sup>	<b>Sensor</b>	REED	<b>Output</b>	Pure contact, normally open	<b>Operating voltage</b>	5 ÷ 240 Vac / Vdc	<b>Switching current (max.)</b>	500 mA	<b>Contact rating (max.)</b>	10 W	<b>Voltage drop (max.)</b>	0,5 V	<b>Visual indicator</b>	None	<b>Operating frequency</b>	200 Hz	<b>Temperature range</b>	-10 ÷ +140 °C	<b>Enclosure classification (IEC 60529)</b>	IP67	<b>Protection circuit</b>	None	<b>Mounting</b>	Only with braket CC SHT
<b>Code</b>	SHT-21																												
<b>Version</b>	Cable 2 x 0,14 mm <sup>2</sup>																												
<b>Sensor</b>	REED																												
<b>Output</b>	Pure contact, normally open																												
<b>Operating voltage</b>	5 ÷ 240 Vac / Vdc																												
<b>Switching current (max.)</b>	500 mA																												
<b>Contact rating (max.)</b>	10 W																												
<b>Voltage drop (max.)</b>	0,5 V																												
<b>Visual indicator</b>	None																												
<b>Operating frequency</b>	200 Hz																												
<b>Temperature range</b>	-10 ÷ +140 °C																												
<b>Enclosure classification (IEC 60529)</b>	IP67																												
<b>Protection circuit</b>	None																												
<b>Mounting</b>	Only with braket CC SHT																												
<p>SHT-21 / Sensor in Al, cable in PTFE - 1 piece each package</p>																													

THREADED CONNECTORS TYPE Y082LC

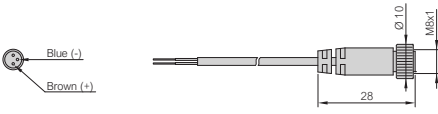
<p><b>Y082LC ...</b> Threaded connectors - 2 poles</p>	<p><b>Technical features</b></p>																								
	<table border="1"> <tr> <td><b>Code</b></td> <td>Y082LC250C</td> <td>Y082LC500C</td> </tr> <tr><td><b>Threaded connectors</b></td><td colspan="2">M8 x 1</td></tr> <tr><td><b>Cable</b></td><td colspan="2">2 x 0,14 mm<sup>2</sup></td></tr> <tr> <td><b>Cable length</b></td> <td>2500 mm</td> <td>5000 mm</td> </tr> <tr><td><b>Operating voltage (max.)</b></td><td colspan="2">50 Vac / 60 Vdc</td></tr> <tr><td><b>Corrente (max.)</b></td><td colspan="2">3000 mA</td></tr> <tr><td><b>Temperature range</b></td><td colspan="2">-25 ÷ +75 °C</td></tr> <tr><td><b>Enclosure classification (IEC 60529)</b></td><td colspan="2">IP67</td></tr> </table>	<b>Code</b>	Y082LC250C	Y082LC500C	<b>Threaded connectors</b>	M8 x 1		<b>Cable</b>	2 x 0,14 mm <sup>2</sup>		<b>Cable length</b>	2500 mm	5000 mm	<b>Operating voltage (max.)</b>	50 Vac / 60 Vdc		<b>Corrente (max.)</b>	3000 mA		<b>Temperature range</b>	-25 ÷ +75 °C		<b>Enclosure classification (IEC 60529)</b>	IP67	
<b>Code</b>	Y082LC250C	Y082LC500C																							
<b>Threaded connectors</b>	M8 x 1																								
<b>Cable</b>	2 x 0,14 mm <sup>2</sup>																								
<b>Cable length</b>	2500 mm	5000 mm																							
<b>Operating voltage (max.)</b>	50 Vac / 60 Vdc																								
<b>Corrente (max.)</b>	3000 mA																								
<b>Temperature range</b>	-25 ÷ +75 °C																								
<b>Enclosure classification (IEC 60529)</b>	IP67																								
<p>Y082LC ... / Connector in PVC, contacts in gilded brass, cable in PVC - 1 piece each package</p>																									

THREADED CONNECTORS TYPE Y083LC

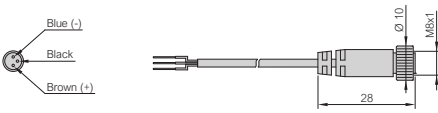
<p><b>Y083LC ...</b> Threaded connectors - 3 poles</p>	<p><b>Technical features</b></p>																								
	<table border="1"> <tr> <td><b>Code</b></td> <td>Y083LC250D</td> <td>Y083LC500D</td> </tr> <tr><td><b>Threaded connectors</b></td><td colspan="2">M8 x 1</td></tr> <tr><td><b>Cable</b></td><td colspan="2">3 x 0,14 mm<sup>2</sup></td></tr> <tr> <td><b>Cable length</b></td> <td>2500 mm</td> <td>5000 mm</td> </tr> <tr><td><b>Operating voltage (max.)</b></td><td colspan="2">50 Vac / 60 Vdc</td></tr> <tr><td><b>Corrente (max.)</b></td><td colspan="2">3000 mA</td></tr> <tr><td><b>Temperature range</b></td><td colspan="2">-25 ÷ +75 °C</td></tr> <tr><td><b>Enclosure classification (IEC 60529)</b></td><td colspan="2">IP67</td></tr> </table>	<b>Code</b>	Y083LC250D	Y083LC500D	<b>Threaded connectors</b>	M8 x 1		<b>Cable</b>	3 x 0,14 mm <sup>2</sup>		<b>Cable length</b>	2500 mm	5000 mm	<b>Operating voltage (max.)</b>	50 Vac / 60 Vdc		<b>Corrente (max.)</b>	3000 mA		<b>Temperature range</b>	-25 ÷ +75 °C		<b>Enclosure classification (IEC 60529)</b>	IP67	
<b>Code</b>	Y083LC250D	Y083LC500D																							
<b>Threaded connectors</b>	M8 x 1																								
<b>Cable</b>	3 x 0,14 mm <sup>2</sup>																								
<b>Cable length</b>	2500 mm	5000 mm																							
<b>Operating voltage (max.)</b>	50 Vac / 60 Vdc																								
<b>Corrente (max.)</b>	3000 mA																								
<b>Temperature range</b>	-25 ÷ +75 °C																								
<b>Enclosure classification (IEC 60529)</b>	IP67																								
<p>Y083LC ... / Connector in PVC, contacts in gilded brass, cable in PVC - 1 piece each package</p>																									

**FIXING BRACKET TYPE CC SHT**

CC SHT ... Fixing bracket for SHT-21 end of stroke sensor	Bore mm	Code	L	Set head screw for fixing to sensor	Set head screw for fixing to cylinder
	32	CC SHT 032	12	M2,6 x 6	M4 x 10
	40	CC SHT 040	12	M2,6 x 6	M4 x 10
	50	CC SHT 050	12	M2,6 x 6	M4 x 10
	63	CC SHT 063	12	M2,6 x 6	M4 x 10
	80	CC SHT 080	12	M2,6 x 6	M4 x 10
	100	CC SHT 100	12	M2,6 x 6	M4 x 10
	125	CC SHT 125	12	M2,6 x 6	M4 x 10

CC SHT ... Anodized aluminium / 1 piece each package + 1 set head screw for fixing to sensor SHT + 1 set head screw for fixing to cylinder



---

**BONESI PNEUMATIK** manufactures all its own products in Italy

---



---

**BONESI PNEUMATIK s.r.l.**

Via A. Robino n. 117  
20025 Legnano (MI) Italy  
P.I. / C.F. 10396340159  
R.E.A. 1373315

[www.bonesipneumatik.it](http://www.bonesipneumatik.it)  
[info@bonesipneumatik.it](mailto:info@bonesipneumatik.it)  
Phone +39 0331 448000  
Telefax +39 0331 448070

